

COMPLEMENTARY PRODUCTS

MIXING EDUCTORS

UPB

These eductors are the ideal devices for the continuous blending of liquids or solutions contained in tanks, when settling of heavier components and local variations of density must be avoided.

Stainless steel types are often used for steam heating processes in water tanks. The distinctive design incorporates the efficiency of the Venturi profile into a body with high structural strength, where the eductor is cast or moulded offering sturdy thick sections. This minimizes the danger of the eductor being damaged in the course of maintenance work.

Maximum operating temperature LT 80° C (PP) - 90° C (PVDF)

- Materials B31 AISI 316L Stainless steel
- D6 PP, chemically bonded fiberglass
- D82 PVDF, moulded (3/8" Parallel Male thread)

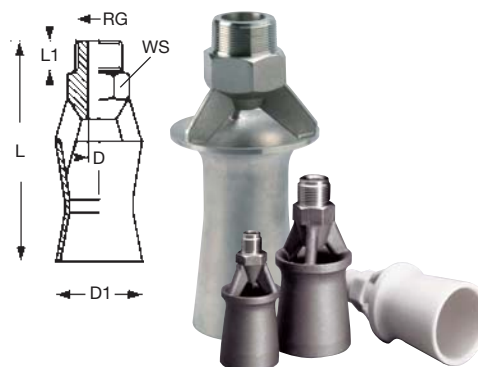

Code	RG inch	D mm	Flow rate at pressure					lpm bar	D1 mm	L mm	L1 mm	WS mm
			1,0	2,0	3,0	4,0	5,0					
UPB C070 B31Sx UPB C070 D6Sx	3/8	7,0	34	48	59	68	76	45	98	15	22	
UPB E100 B31Rx UPB E100 B31Sx UPB E100 D6Sx	1/2	10	63	89	109	126	141	60	132	20	30	
UPB H150 B31Sx	3/4	10	63	89	109	126	141	60	132	20	30	
UPB K200 B31Sx	1 1/2	15	155	220	268	310	346	80	230	30	60	
UPB K200 B31Sx	2	20	206	287	357	410	460	102	295	30	70	

x = Thread Codes
B = BSPT, S. Steel only - **G = BSPP**, PP and PVDF - **N = NPT**, all materials

The table aside shows the eductor water capacity as a function of the pressure drop between the inlet pressure and the outlet back pressure. See the diagram beside for steam heating, full lines show Heat Quantity, broken lines Steam Capacity, as a function of feed pressure.

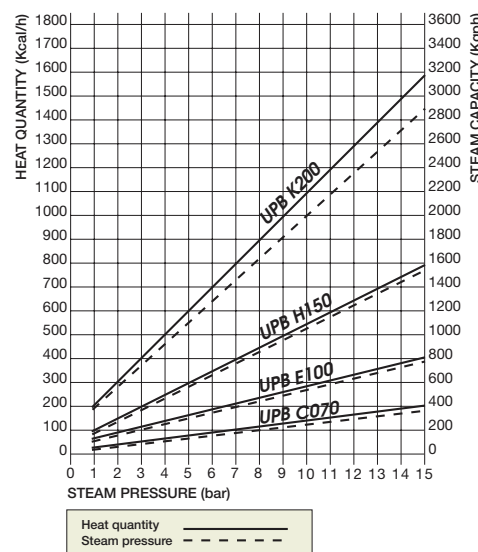

The graph on the left shows the effective range of type UPB E100, as tested in a water tank at 50 cm depth. Under normal working conditions, for feed pressure values between 2 and 4 Bar, eductors with a total capacity equal to 20% of the liquid volume to be agitated has proven adequate for most applications. Detailed suggestions about eductor layouts inside tanks are shown in product Data Sheet.

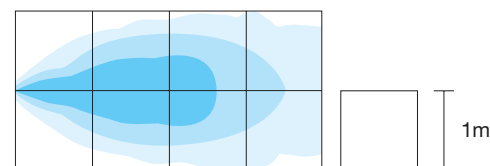

MIXING EDUCTORS

UPD

UPD series eductors are similar to the UPB series, the only difference is that they are supplied with a female thread connection. This design offers the advantage of an easier removal from the feed pipe, should the eductor be broken while the plant is serviced.

- Materials B31 AISI 316L Stainless steel
- D6 PP, chemically bonded fiberglass LT 80° C (PP)

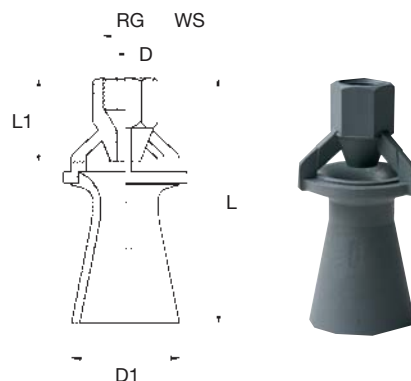

Code	RF inch	D mm	Flow rate at pressure					lpm bar	D1 mm	L mm	L1 mm	WS mm
			1,0	2,0	3,0	4,0	5,0					
UPD E100 D6xx	3/4	10	63	89	109	126	141	75	147	30	34	
UPD H150 D6Sxx	1 1/2	15	141	199	243	280	313	80	225	45	60	
UPD H150 B31Sxx	1 1/2	15	141	199	243	280	313	80	239	83	60	
UPD K200 B31Sxx	2	20	206	287	357	410	460	102	295	83	70	

XX = Thread Codes
 SG = BSP SN = NPT

