

ASSEMBLY ACCESSORIES

ZAA/ZAB

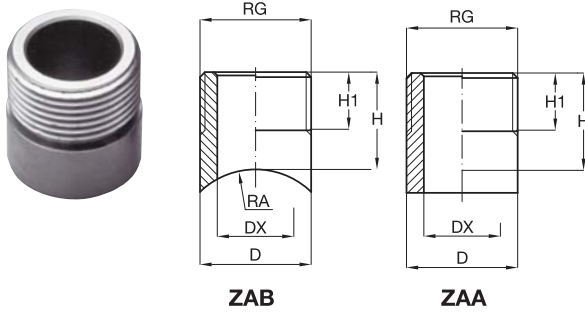

Materials B1 AISI 303 Stainless steel  
B31 AISI 316 L Stainless steel

Radiused nipples

We offer nipples with a radiused base for an easier and faster welding to the manifold pipe. See RA values for radius in the table here beside.

NIPPLES

ZAA welding nipples allow the assembly of GX, BX or KX series nozzle tips on pipes and spray manifolds. The 3/8" BSPP threaded nipple meets filters of the VEA, VEC, VED series for the protection of single nozzle tips. Welding nipples can be supplied radiused for the welding connection. The radius values are listed as RA in the code table.

| Code | RG<br>inch | H<br>mm | H1<br>mm | D<br>mm | DX<br>mm | RA<br>mm | W<br>g |
|------|------------|---------|----------|---------|----------|----------|--------|
|------|------------|---------|----------|---------|----------|----------|--------|

Standard

|             |     |    |    |    |      |   |    |
|-------------|-----|----|----|----|------|---|----|
| ZAA C018 xx | 3/8 | 18 | 10 | 17 | 11,5 | - | 20 |
| ZAA E027 xx | 3/4 | 27 | 15 | 27 | 18,0 | - | 61 |

Radiused

|              |     |    |    |    |      |      |    |
|--------------|-----|----|----|----|------|------|----|
| ZAB C018 xxD | 3/8 | 18 | 10 | 17 | 11,5 | 10   | 20 |
| ZAB C018 xxE |     |    |    |    |      | 12,5 |    |
| ZAB C018 xxF |     |    |    |    |      | 16   |    |
| ZAB C018 xxG |     |    |    |    |      | 20   |    |
| ZAB C018 xxH |     |    |    |    |      | 25   |    |

ZAC

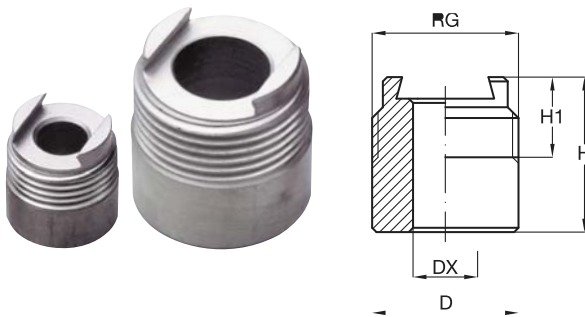

Material B31 AISI 316 L Stainless steel

NIPPLES

ZAC welding nipples are manufactured with a matching dovetail end, to host GY dovetail nozzle tips and keep them pointed in the desired position.

| Code | RG<br>inch | H<br>mm | H1<br>mm | D<br>mm | DX<br>mm | W<br>g |
|------|------------|---------|----------|---------|----------|--------|
|------|------------|---------|----------|---------|----------|--------|

|             |       |      |    |    |     |     |
|-------------|-------|------|----|----|-----|-----|
| ZAC C018 xx | 3/8   | 18   | 10 | 17 | 7,5 | 20  |
| ZAC E027 xx | 3/4   | 27,5 | 14 | 27 | 14  | 61  |
| ZAC G040 xx | 1 1/4 | 40   | 21 | 42 | 20  | 280 |

ZLA / ZLC

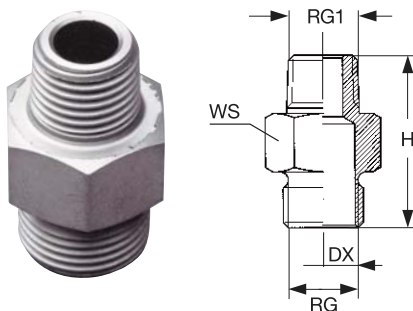

Materials B31 AISI 316 L Stainless steel  
T1 Brass

NIPPLES

ZLA series nipples feature a male BSPT thread on the inlet side and meet VEA, VEC, VED filters for the protection of single nozzle tips (whereas the others are cone-shaped). Unlike those of smaller size, the ZLC 7575 nipples have both male threads straight BSP.

| Code | RG<br>inch | RG1<br>inch | DX<br>mm | H<br>mm | WS<br>mm | W<br>g |
|------|------------|-------------|----------|---------|----------|--------|
|------|------------|-------------|----------|---------|----------|--------|

|              |     |     |     |      |    |    |
|--------------|-----|-----|-----|------|----|----|
| ZLA 3825 xxB | 3/8 | 1/4 | 7,5 | 32,5 | 19 | 25 |
| ZLA 3838 xxB | 3/8 | 3/8 | 10  | 35   | 19 | 25 |
| ZLC 7575 xxB | 3/4 | 3/4 | 18  | 35   | 32 | 90 |